

**OPERATING INSTRUCTIONS FOR  
VP 418SV2-650FB-CC SpinVessel®**

**US Patent #11,623,188  
European (BE, FR, DE, NL, CH, SE, & UK) Patent #3887049**

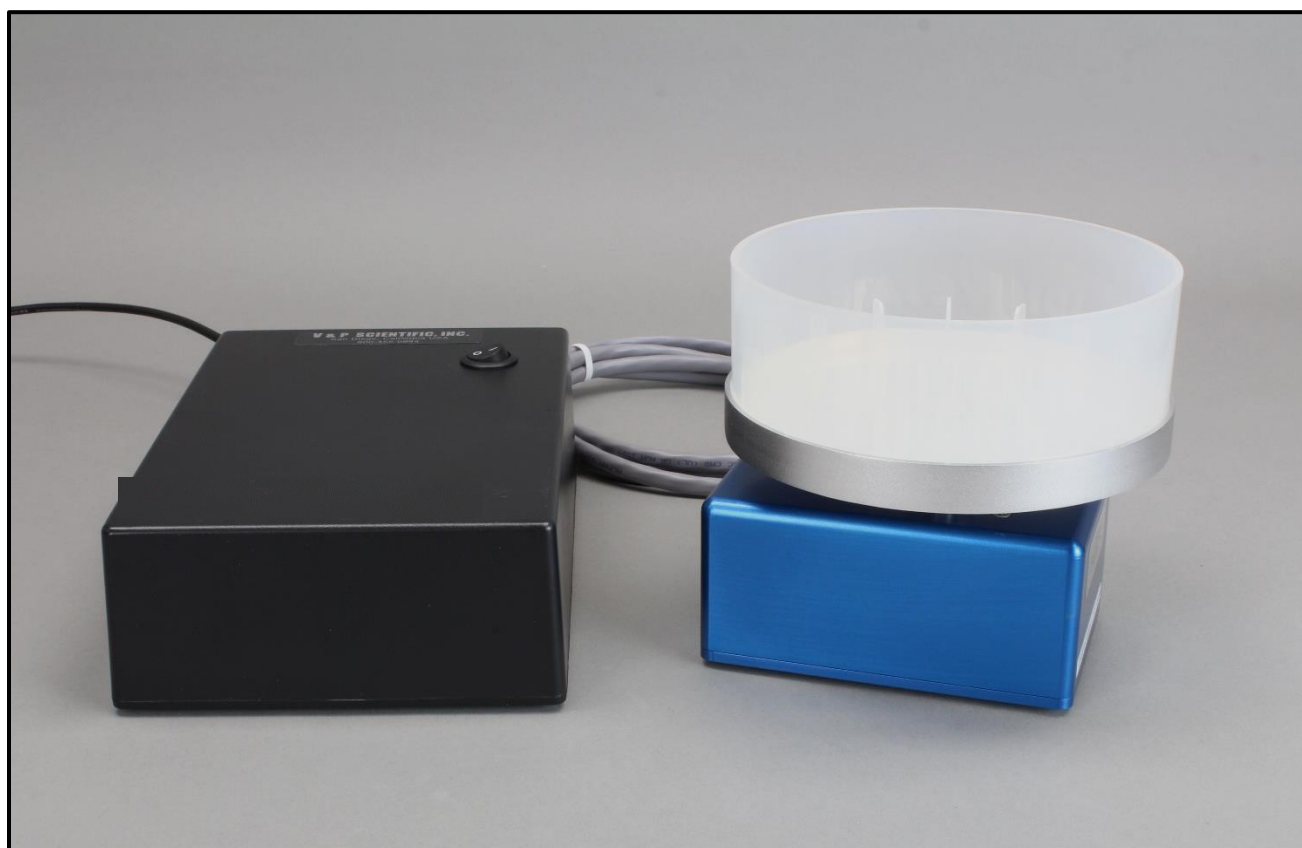

**SpinVessel® System with Computer Control feature for 650ml SpinVessel® Tube:  
VP 418SV2-1-650FB-CC includes Motor Unit, Spin Base, Controller, Power Supply (not shown),  
Registration Disc (not shown), USB cable and USB drive with control software (not shown). Shown with  
SpinVessel® Tube, VP 830SV-650FB, sold separately.**

# SET-UP

## CONNECTING PARTS OF THE SpinVessel® SYSTEM

### Power and Controller Connections

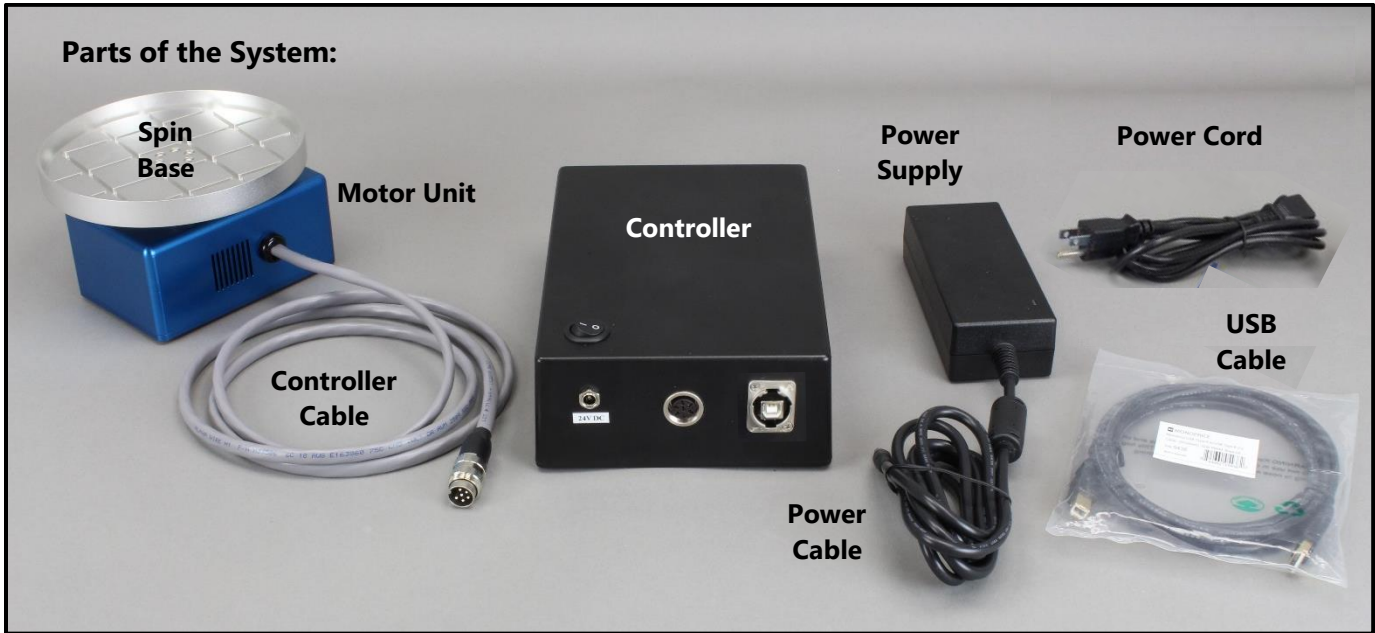

1. Place Motor Unit on a sturdy lab bench, table or robotic work station. Note that Z height with tube is 136mm (rubber feet not included).

**Warning: Do not use the Spin Base as a handle to move the SpinVessel. Hold the Motor Unit with both hands to position the SpinVessel where desired.**

2. Since Controller Cable is 6 feet long, Controller and computer can be placed at a distance from the Motor Unit.

3. Connect Power Cord from Power Supply to an outlet.

**Warning:** Do not plug Controller in while power is on. Ensure that the Power Switch is in the off position ("0" is down). Always have Controller plugged in before powering up.

4. Connect Power Cable from Power Supply to Controller.

5. Connect Controller Cable from the Motor Unit to the Controller.

6. Connect the USB Cable from the Controller to the computer.

7. Place one VP 830SV-650CFB SpinVessel® tube into the Spin Base. Ensure that the SpinVessel® tube is seated securely within the Spin Base.



## ALIGNING PIPET TIPS TO THE SpinVessel® TUBE



Place SpinVessel® motor unit in desired location on an automated liquid handler in a microplate holder. See drawings on next page to assist in this step.

*The motor unit is SLAS format (127.7mm x 85.5mm) which will fit into any SLAS plate locator or carrier.*



To align pipet tips to inside of SpinVessel® tube, use the registration disc. Place disc on top of the drive base, not the tube. Lower the pipet tips until they just touch the disc. Align robot tips to the holes. This registers the pipet head to the SpinVessel® and prevents the pipet tips from hitting the SpinVessel projections.

*Z height needs to be adjusted with tube in place.*

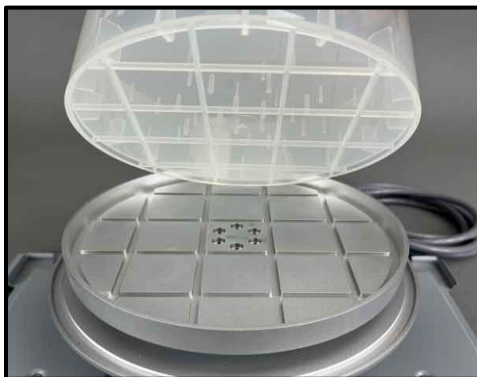

Insert the SpinVessel® tube VP 830SV-650FB into the SpinVessel® spin base.

*Ensure that the SpinVessel® tabs are seated flat and registered to the slots in the aluminum spin base. SpinVessel® tube should not rotate within the spin base.*

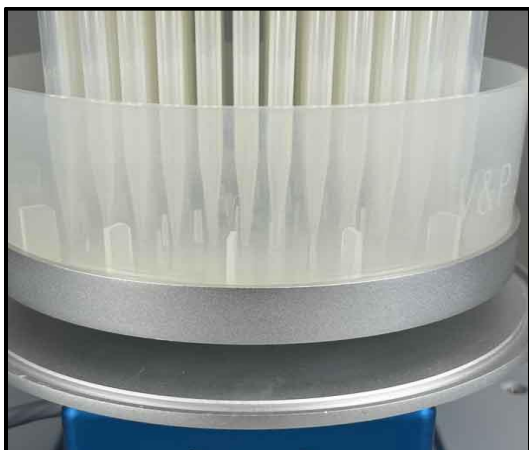

With the SpinVessel® tube in the drive base, check the tip alignment relative to the projections.

*Without liquid in the tube, turn on the SpinVessel® to make sure the tips are not hitting the projections.*

**DRAWINGS OF SpinVessel® SYSTEM with THE SpinVessel® TUBE**

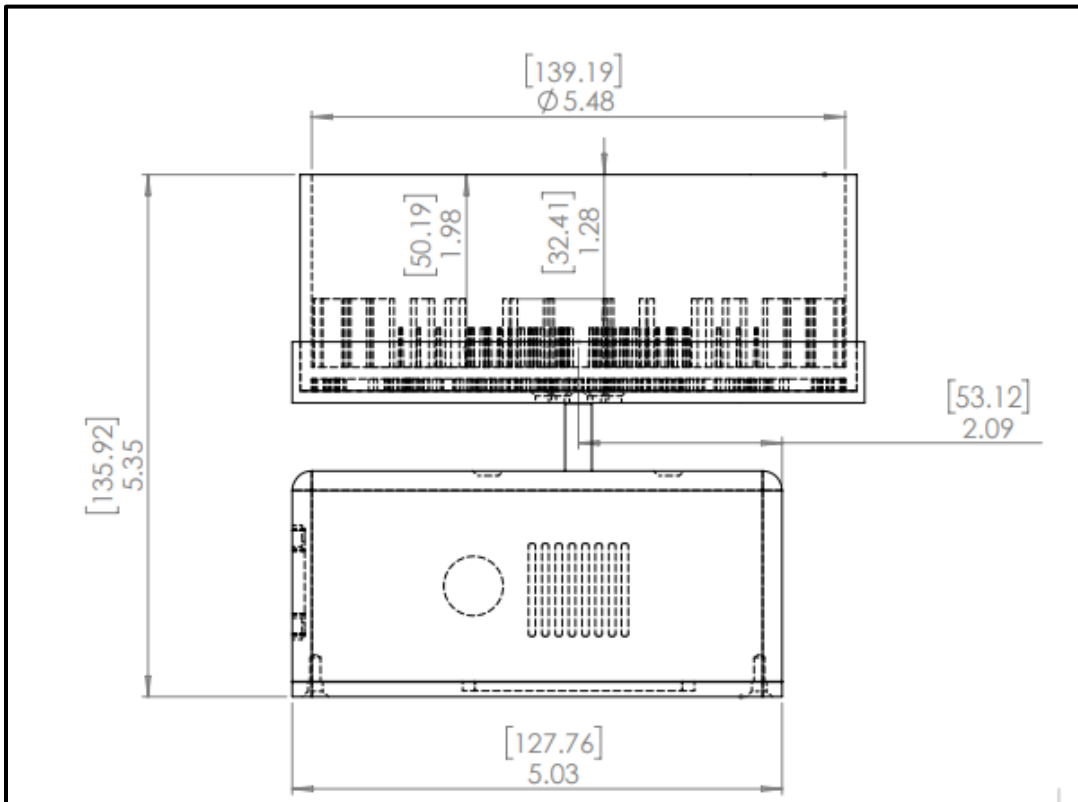
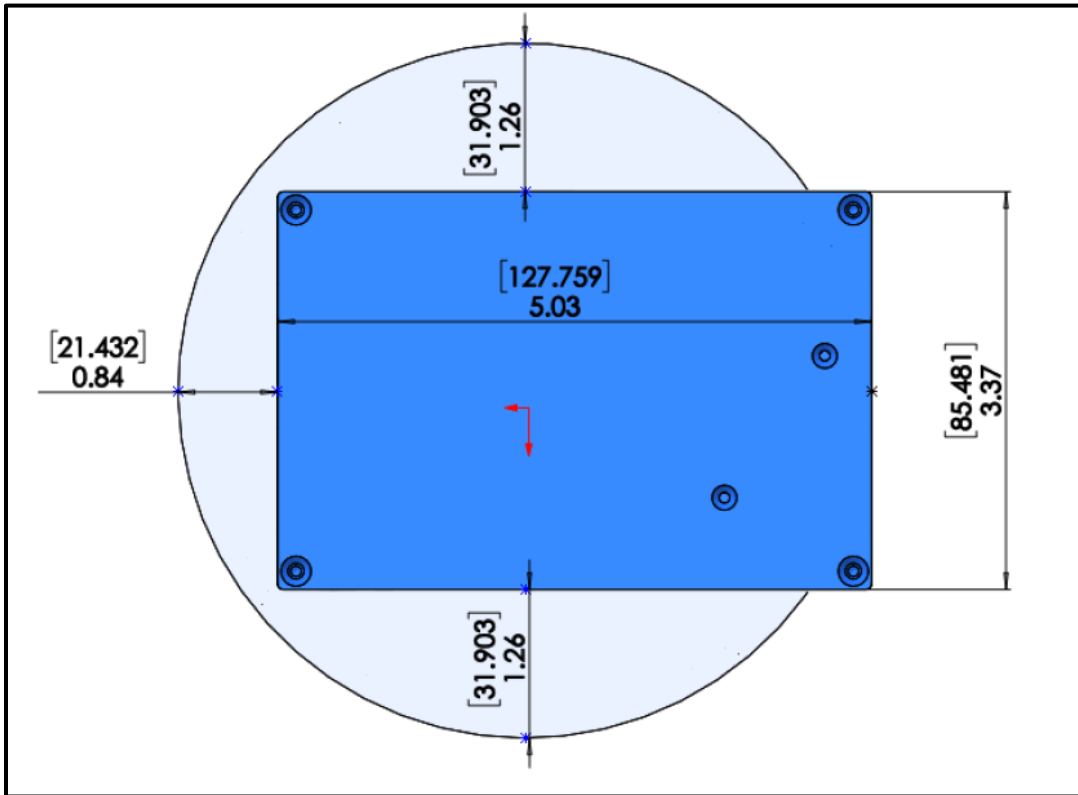

## **OPERATION**

### **POWERING UP THE SpinVessel® SYSTEM**

The Power Switch (I/O) is located on the back of the Controller. To power up the Controller, depress the "I" of the switch.

### **OPERATING THE SpinVessel® With COMPUTER CONTROL**

The SpinVessel® Models with "-CC" in the part number are controlled using a computer. The Controller for the computer controllable SpinVessel® is connected by a USB communication cable to a computer. The Controller accepts simple ASCII commands to set the speed of the rotations, the number of rotations (including fractions of a rotation), duration of pause before reversing direction and degree of ramping to speed set.

#### ***Software details***

1. The SpinVessel® Controller uses an internal CH340G USB to Serial Converter (set to 9600,8,N,1) which will require driver software. Windows may already have the needed USB driver software installed. If not, download the "CH340 USB DRIVER" from the provided USB flash drive and run "CH341SER.exe" to install it (Windows typically auto-installs once downloaded). If your company policy does not allow the use of the provided USB stick, this driver is also available for download from the internet (contact your IT department for assistance if necessary).
2. The basic command language for this computer-to-stirrer communication is ASCII.
3. Commands can be sent from the computer using a standard terminal program like HyperTerminal or Realterm. Or, if needed, download the V&P Scientific Serial Terminal program from the provided USB flash drive. If your company policy does not allow the use of the provided USB stick, we suggest asking your IT department for a recommendation.
4. Alternatively, the ASCII commands can be sent by an automated liquid handler's software to control the SpinVessel®. Since there are many different automated liquid handlers available, please contact a technical representative from the company that makes the liquid handler.

#### ***Connecting and sending commands***

1. Set up the system as described in the Set-Up section of the SpinVessel® Technote with the USB cable connected to the computer to be used.
2. Open the Serial Terminal program (V&P Scientific version or other).

3. Turn on the SpinVessel® instrument as described.
4. Select the appropriate COM port and click CONNECT to establish a line of communication between the instrument and the computer.
5. Create ASCII command strings as outlined in the diagram shown below to control the instrument with the following parameters:
  - a. Speed of rotation in revolutions per minute (RPM).
  - b. Number of rotations before reversing direction.
  - c. Fraction of a rotation (input 0-9 for fractions of a rotation).
  - d. Pause, in milliseconds, before reversing direction.
  - e. Ramping, 0-100, where 0 is no ramping (rapid acceleration) and 100 is full ramping (slow acceleration)
6. Hit ENTER to send command and start rotation of the SpinVessel® instrument.
7. To stop, type <0> and hit ENTER.

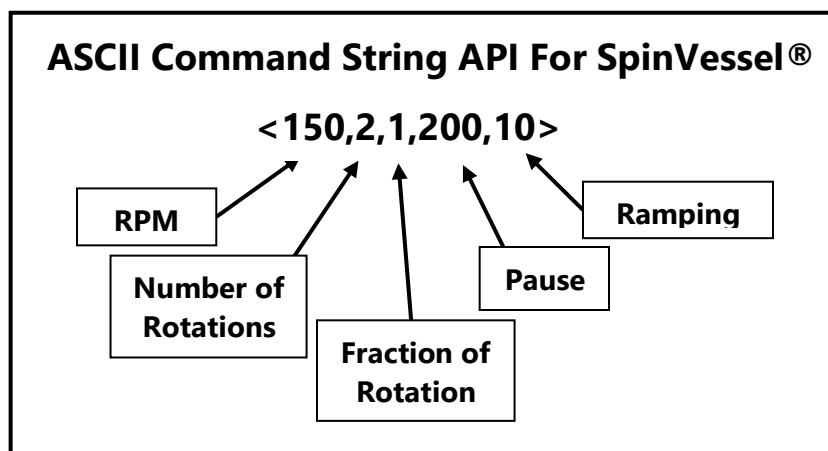

## USING A 650 ML SpinVessel® SYSTEM

**The optimal stirring mode is dependent upon the application and needs to be empirically determined.**

Factors to consider in determining optimal 650 mL SpinVessel® operation are the density of the particulates, their size and shape, as well as the volume and viscosity of the liquid. Start with 150 RPM and 2.1 rotations before reversing direction, then work up to the appropriate RPMs and number of rotations for the particulate's density, fragility, and solution viscosity. We have found that smaller circumference SpinVessels® require higher RPMs than larger circumference SpinVessels do, because the critical factor is the linear speed generated at the circumference not the RPMs. See page 501 of our [SLAS Technology paper](#) for a discussion of this phenomenon.

The following are settings to use with an aqueous solution when first testing the VP 418SV-650FB-CC SpinVessel®:

**Speed: 150 RPM    Rotate: 2.1    Pause: 200 milliseconds    Ramp: 10%**

It is always a good idea to practice with water in your SpinVessel to determine safe RPM, Rotation, Pause and Ramp numbers before you use expensive reagents.

**Note: If Ramp is set to 0, water will splash out of the 650 ml Spin Vessel.**

The VP 418SV-1-650FB-CC SpinVessel® is designed to be used only with a VP 830SV-650FB SpinVessels® tube. Please contact V&P Scientific for pricing.

See below for an example of low versus high RPM for a solution of yeast cells in a large circumference 6 liter SpinVessel®. Note: When given a longer mixing time even the slower speed (20 RPM i.e., – more gentle mixing) was still able to suspend the yeast cells.

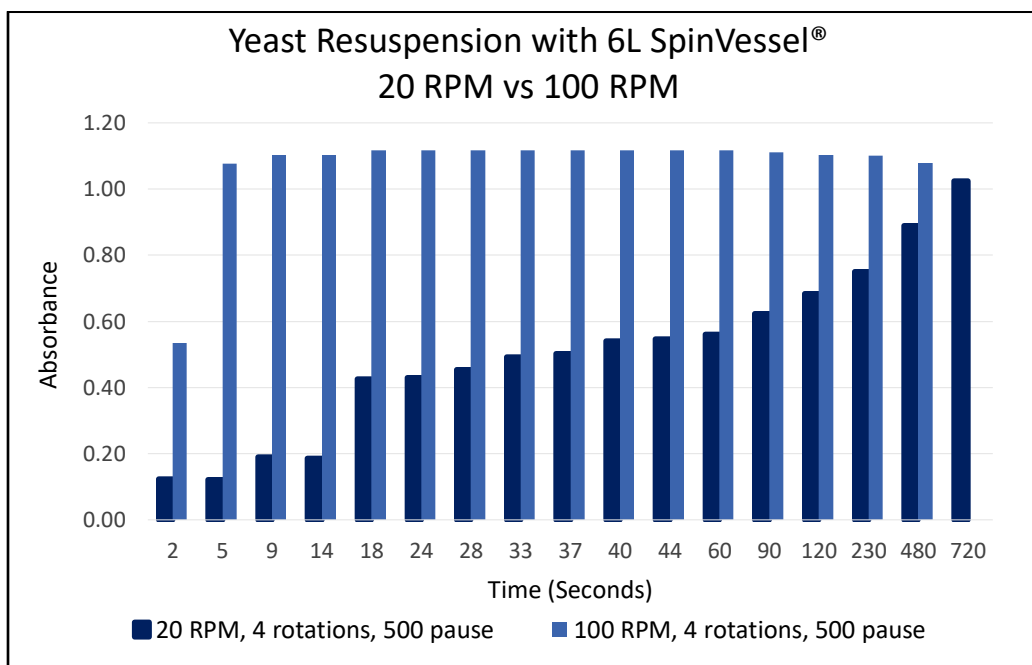



## PRODUCT MAINTENANCE

### GENERAL PRODUCT CARE

When not in use, turn the power switch off.

Do not place the control unit in chambers with temperatures above 40°C.

To clean the stirrer, wipe down with a cloth and mild detergent followed by a water wipe. **Do not immerse SpinVessel® Motor or Control in liquid.**

The motor of the VP 418SV-650FB-CC SpinVessel® is a stepper motor, 100-240 Volts, 50/60 Hz, CE compliant.

### SAFETY PRECAUTIONS

The use of motor controls, like that of all utilization of concentrated power, is potentially hazardous. The degree of hazard can be greatly reduced by proper design, selection, installation, and use, but all hazards cannot be completely eliminated.

The following safety precautions must be observed during all phases of installation, operation, service, and repair of this motor control product. Failure to comply with these precautions or with specific warnings elsewhere in this manual violates safety standards of design, manufacture and intended use of the products. V&P Scientific assumes no liability for the customer's failure to comply with safety requirements and practices.

<b>WARNING</b>
To avoid personnel injury caused by electrical shock, do not remove the cover of the controller when the power is ON.
<b>CAUTION</b>
Do not disconnect motor during operation. Otherwise, over-current breakdown may result.

### WARRANTY

V&P Scientific, Inc. warrants this product to be free from defects in material and workmanship when used under normal laboratory conditions for one year. This warranty begins from the date of delivery by V&P Scientific.

In the event this product fails under normal laboratory conditions within the specified period of time because of a defect in material or workmanship, V&P Scientific will, at its option, repair or replace the product. Damage to the product caused by user negligence is not covered.

This warranty is made in lieu of other warranties expressed or implied including the warranties of merchantability and fitness for a particular purpose. V&P Scientific shall not be liable for loss or damages arising from the use of these products nor for consequential damages of any kind.

Please keep the special shipping carton in case the unit needs to be shipped back to V&P Scientific. Contact V&P Scientific for return authorization and shipping instructions or for any other assistance at 858-455-0643 or [sales@vp-sci.com](mailto:sales@vp-sci.com).